

ENVIROLIFT

WATER LIFTING



ARCHIMEDES SCREW PUMP

DESCRIPTION / OPERATION

The Envirolift water lifting screws, or called screw pumps, are designed according to the Archimede principle. This principle consists of making 1 to 3 threads around a central rotor, which in an inclined position, and in a suitable rotational movement, ensures the rise of the water to a higher level.

This technology is insensitive to variations in flow rates and waste, that the effluent may contain. Under certain extreme conditions, however, a protective grid may be added. To facilitate its implementation, it is recommended to add of a metal trough.

This is the oldest water lifting technology, and its lifespan remains unmatched compared to any other system. Even in the case of operation without water (test, maintenance, negligence or to clear a control by level probes), there is no risk of deterioration of the equipment. On the other hand the power consumption is less than with a classical pump.



CENTRAL TUBE

The diameter and the thickness of the central tube are calculated in function of the external diameters, the length and the inclination of the lifting screw, but also according to the number of spirals.

SCREW

The diameter, pitch, and number of screws are calculated according to the desired flow and height of lift, taking into account the geometry of installation. The screw absorb the flow which arrives at the foot to maintain it to the upper part. This is within the limit of the capacity for which it has been dimensioned. It is a so-called volumetric pump.

TROUGH

The trough of the lifting screw is traditionally made of concrete by the civil engineer. This is a rather delicate operation. For this reason, we offer metal troughs that are particularly well suited and which ensure the perfect alignment of the screw with respect to its trough. Implementation is therefore much simplified.

DRIVING

The power of the drive unit is calculated in relation to the geometrical characteristics of the lifting screw and its maximum flow. It is an essential component that must be perfectly aligned with the screw axis.

MATERIAL

Construction in stainless steel 304L or 316L

PERFORMANCES

	Flow rates(m ³ /h)
Models	Diameter from 300 to 3000 mm
Capacity	Up to 11000 m ³ /h per unit

SPECIFICITIES

- Large range of flow rates
- Flexible to flow rate variation
- Not sensitive to waste
- Design with and without trough
- Up to 3 m diameter and 20 m length
- Lifespan over 30 years
- Faible coût d'entretien

LAY-OUT

- 1 Water lifting screw
- 2 Lower bearing
- 3 Trough (Option)
- 4 Motorisation / Upper bearing
- 5 Effluent outlet
- 6 Effluent inlet

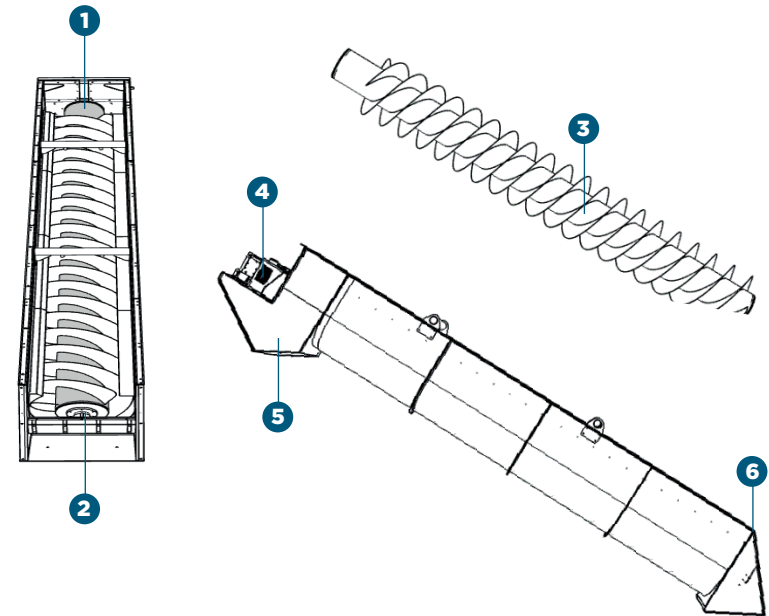

DIMENSIONS

	Overall dimensions in mm
Models	EVM 300 to EVM 3000
Screw diameter	From 300 to 3000 mm
Length	Lenth up to 20 meters

A STEP AHEAD IN WATER TECHNOLOGY

sfa-enviro.com

 [@sfa_enviro](https://twitter.com/sfa_enviro)

